

Leveling System Controlled by Electro-hydraulic Proportional Valves in self-propelled modular transporter (SPMT)

Lu Liqun, Wang Xiuqing, Wang Hantao

Abstract—Self-propelled modular transporter (SPMT) is provided with a hydraulic leveling system to ensure the stability and balance loads on uneven road surfaces. The suspension lift system characteristics and working principle of SPMT is studied, three-point leveling and four-point leveling apply for different working conditions are analyzed and the control strategies and methods of leveling system are explained. A lifting suspension leveling system of 150t SPMT is designed, which adopted Rexroth electro-hydraulic proportioning multi-way direction valve with load-sensing as core control elements. The result shows that control accuracy of the designed leveling system is improved and energy savings is achieved.

Index Terms—Self-propelled modular transporter, Leveling system with lifting suspension, Electro-hydraulic proportional control, Multi-way direction valve, Load sensing.

1 INTRODUCTION

Self-propelled modular transporter(SPMT) often carries heavy and oversized goods. It may cause not only damage to the axle but also result in vehicle overturning when the center of goods deviates from the geometric center of the body[1][2]. Therefore, loading platform of SPMT designed with hydraulic lifting system can lift and suspend in a certain range[3]. The functions such as load platform leveling, center of gravity display and automatic adjustment when encountered uneven road allow SPMT to load and unload goods easily and enhance vehicle passing ability. At the same time, it is also beneficial to passing through road obstacles.

Taking 150t SPMT with 6-axis as an example, the working principle and control strategies of leveling on the suspension system was analyzed and a leveling system controlled by electro-hydraulic proportional valves was designed, which provide engineering reference for the design of leveling system in SPMT.

2 ANALYSIS OF LEVELING SYSTEM

2.1 The Leveling Principle

Hydraulic leveling system in SPMT is realized by lifting hydraulic cylinders on the suspension system, using hydraulic suspension to achieve the function of force transmission, damping and platform lifting, leveling under the instruction of PLC control system[4]. Suspension cylinder is divided into different support groups through opening and closing of hy-

draulic ball valve according to stability requirements in different conditions. The suspension cylinder of SPMT can be achieved three or four point supporting technique (as shown in Figure 1 and Figure 2). The circuits of hydraulic cylinder that combined into the same support point are connected with each other which form a closed hydraulic system under the hydraulic control system during vehicle running. When the vehicle is running on uneven road, the closed hydraulic system can make vehicle adapt to the uneven road through the telescopic movement of the cylinder. The balance of load is acquired because each suspension with the same support point group is beard uniformly.

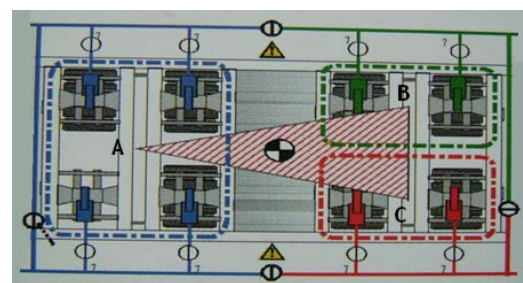

Fig.1 Three-point supporting system

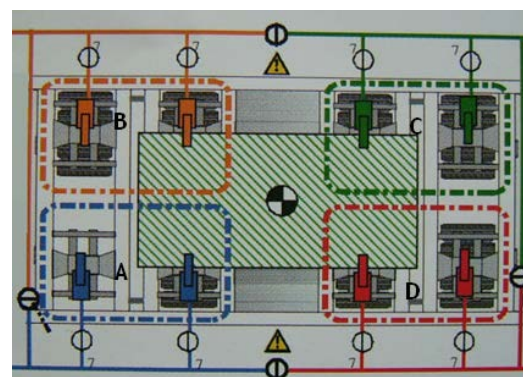

Fig.2 Four-point supporting system

Three-point supporting is applied to uneven road surface

- Lu Liqun is currently working as the associate professor in school of transportation and vehicle engineering in Shandong University of Technology, China, PH-8605332786837. E-mail: luliqunluliqun@yahoo.com
- Wang Xiuqing is currently pursuing masters degree program in Shandong University of Technology, China, PH-8605332786837. E-mail: wangxiuqing456@163.com
- Wang Hantao is currently pursuing masters degree program in Shandong University of Technology, China, PH-8605332786837. E-mail: 609825060@qq.com

and the center of loads must be located inside the triangle formed by three-point supporting. Four-point supporting is applied to the condition of the unbalanced gravity center of load and has a higher requirement on the road surface. Three-point and four-point supporting can be interchanged. Using hydraulic suspension, in addition to providing vehicle lifting and leveling functions, What's more, the telescopic and compensation function of hydraulic cylinders ensures bearing of wheel sets being uniformly and avoiding slipping, accommodating uneven road conditions.

2.2 Control strategies of leveling

Leveling system in SPMT is a control device to adjust the body's tilt attitude, which consists of a controller, an angle sensor, a hydraulic lift system and other auxiliary devices (as shown in Figure 3 taking 4-axis as an example). An angle sensor is installed on each suspension, as the SPMT's ground condition of work is better and can be considered as approximate level, the height of the suspension can be determined by the angle sensor so that the height of each support point is detected. The control expectation is the difference between the other suspension height and the suspension height of refer-

ence and allowable deviation is usually no more than 20mm determined by the engineering practice. The change in rotational angle is measured by the internal potentiometer with the maximum measurement range of $\pm 20^\circ$.

Two operation modes include three-point and four-point supporting can be adopted in vehicle leveling system which the function of vehicle lifting, single-point leveling and front and rear tilt leveling can be realized. In addition, both left and right tilt leveling can be acquired by the four-point supporting. Open-loop control is adopted in single-point leveling. The leveling interface is displayed on LCD screen in the cab when the system is in open-loop leveling control mode. control variable is proportional to the input voltage of the handle and the direction is corresponding with the direction of the handle pushing. Control variable drives hydraulic proportional valve to work and manipulates each hydraulic cylinders of suspension to lift or fall by converting control variable into voltage signal and current signal. Closed-loop control is adopted in vehicle lifting, front and rear tilt leveling and both left and right sides tilt leveling.

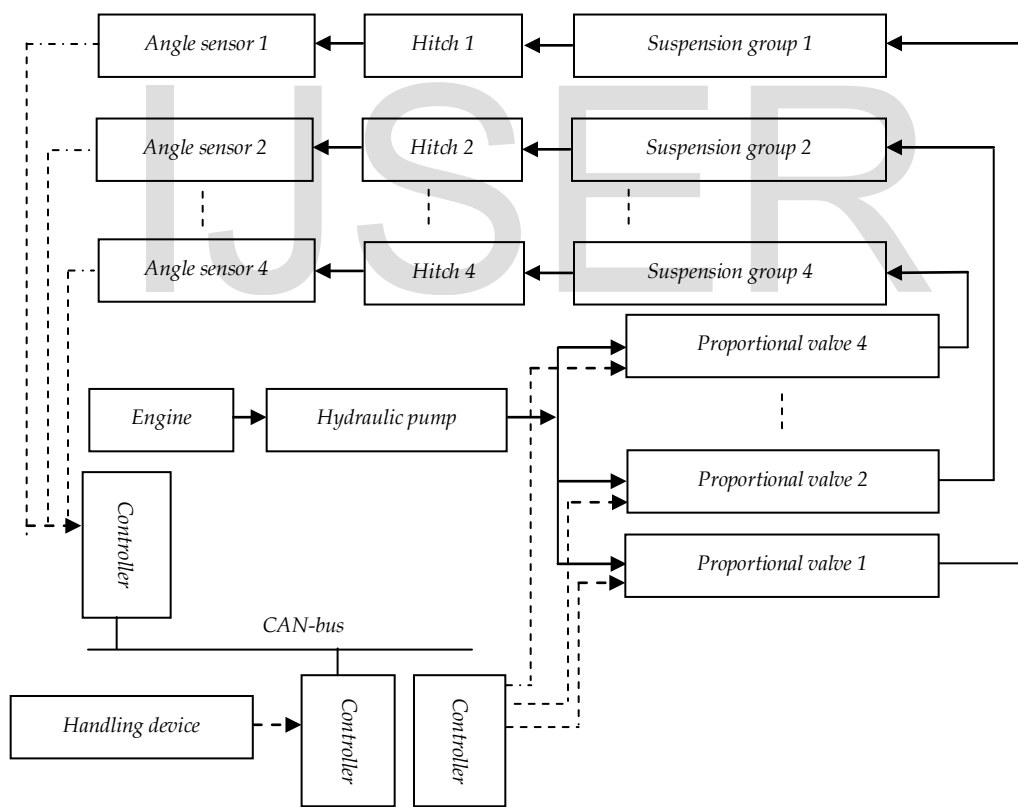

Fig.3 The steering system of SPMT

2.3 Leveling Security Policy

Hydraulic lifting system has a safety device. Each suspension cylinder is connected to hydraulic lines on the body with a rubber hose. if a hose on the cylinder is broken, the supporting point of the cylinder will be failure without a safety device. Therefore, a safety device is consist of two shuttle valves

on each lifting cylinder and there is a hose connecting two shuttle valves. If a hose of lift cylinder is broken, shuttle valves will cut off the oil line of the broken hose automatically, and the other hose still works to ensure the normal operation of the lift cylinder. The characteristic of system is that the frame can be lift in a certain range with reference to the equilibrium position through a hydraulic controlling system.

Four-point support leveling must ensure not only the body's level but also bearing uniformly of four-point support. It is necessary to solve the contradiction between leveling and uniformly supported under redundancy supporting and the mutual coupling between the various support systems when four-point support is adopted. Otherwise, it will cause a phenomenon of "virtual leg" which is one support of the body bears almost no force, the body and the load borne are beard by the other three supports, however this situation is not allowed in the engineering. The bearing range of each support is determined according to the sum of goods and vehicle weight through pressure sensor attached to each suspension loop of platform. The value of each pressure sensor is monitored real time in the process of leveling. If the vehicle is found to have "virtual leg" phenomenon, it should immediately stop leveling. The leveling operation start again after putting the sup-

port of the virtual leg out when the pressure is adjusted to a reasonable value .

3 DESIGN OF LEVELING SYSTEM

3.1 Hydraulic Suspension System with Lifting

The leveling system was designed taking 150T SPMT lifting suspension system as a research object according to the principle and control strategy of the leveling system. During design, hydraulic lifting suspension system and steering system can share the same variable pump , which provides motive force[5][6][7]. The pump is a swash plate axial piston pump with constant power control and load sensing control by cutting off pressure, which is used in open loop hydraulic transmission[8].

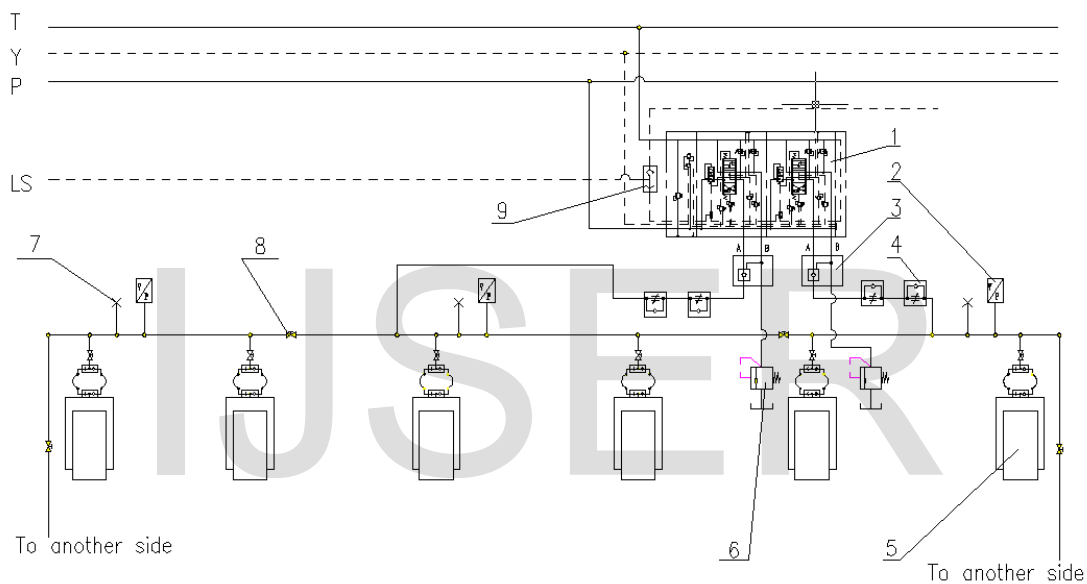

Fig. 4 150t self-propelled modular transporter(SPMT) lifting suspension system (unilateral)

- 1- proportional sandwich directional valve; 2-pressure sensor; 3-pilot operated check valve; 4-throttle and check valves; 5-suspension cylinder; 6- pressure relief valve; 7-measured pressure pipe fitting; 8-ball valve; 9-shuttle valve

The working pressure and the output flow of pump are regulated by constant power control and the engine is protected, which makes the constant power could not exceed the predetermined driving power under the constant driving speed. The function of constant power control starts to work while the pressure is less than the predetermined pressure value[9][10]. The pressure cut off(the constant pressure control)precedes constant power control through reducing the pump's displacement when the pressure reaches a predetermined value. Load sensitive control is realized by a load sensing valve. This valve is a flow control valve, which can adjust the pump according to the load pressure and makes the variable pump meet the actuator's (cylinder or hydraulic motor) need. The schematic diagram of hydraulic lifting suspension system is shown in Figure 4. In order to express the relationship between the various elements clearly, the unilateral control loop of SPMT was drawn in schematic diagram and the

other side is the same as it's.

3.2 Force Analysis on Hydraulic Suspension

The car with 6- axis can carry 150 tons of goods and has itself 40 tons weight, therefore each axis' capacity may up to 32 tons. Each axis is consist of two hydraulic suspension mechanism, so each hydraulic lift cylinder's full load is 16 tons. The lift cylinder bears the maximum force when the vehicle is in full load and the frame is lift to the highest location. Taking the cantilever as the research object, its force diagram is shown in Figure 5 (already marked the known size and angle).

In the Figure:

G – full load of hydraulic suspension $G=160KN$

F – the force of suspension cylinder (KN)

N – hinge constraint reaction (KN)

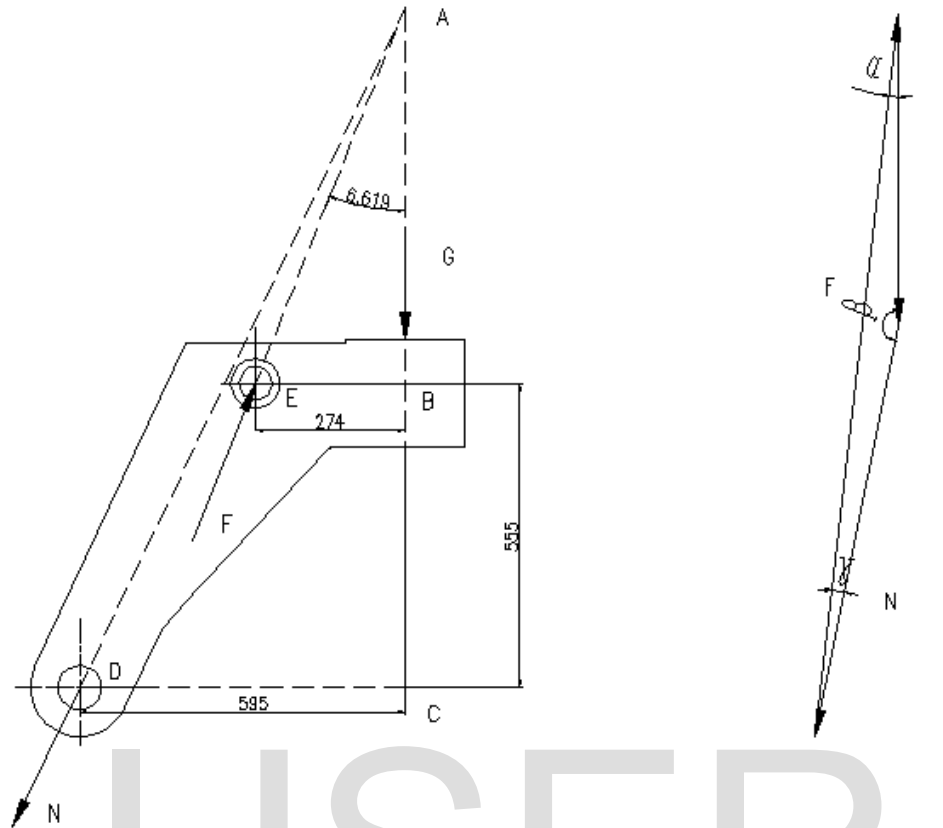

Fig.5 The force analysis on hydraulic cylinder

Rotating arm (neglect its own weight) is in balance under the action of three non-parallel force. From the theorem of three force balance, it can be conclude that t three force must intersect at one point (as shown in Figure 5b) .

From the right triangle $\triangle ABE$ in Figure 5a, then

$$AB = \frac{BE}{\tan 6.619^\circ} = \frac{274}{\tan 6.619^\circ} \approx 2361. (\angle EAB = 6.619^\circ)$$

Then $AC = AB + BC = 2361 + 555 = 2916$
Therefor

$$\delta = \angle DAC = \arctg \frac{CD}{AC} = \arctg \frac{595}{2916} \approx 11.53^\circ$$

$$\text{That is: } \beta = 180^\circ - \angle DAC = 168.47^\circ \\ \gamma = 180^\circ - \alpha - \beta = 4.911^\circ$$

For Fig.5[b], according to the sine theorem:

$$\frac{F}{\sin \beta} = \frac{G}{\sin \gamma} \quad (1)$$

Then:

$$F = \frac{\sin 168.47^\circ}{\sin 4.911^\circ} \times 160 \approx 374 \text{KN}$$

3.3 The Working Pressure of Hydraulic Lifting System

According to the engineering experience, common working pressure on hydraulic components of hoisting machinery

is 20~32Mpa. The working pressure of lifting cylinder is defined as 25Mpa in advance .

$$F = pA = p \cdot \pi D^2 / 4 \quad (2)$$

Where: p —the working pressure of suspension cylinder (Mpa)

D —the plunger diameter of suspension cylinder (mm)

$$\text{Then: } D = \sqrt{\frac{4F}{p\pi}} = 138 \text{mm}$$

Taking design of suspension mechanism into account , plunger diameter of cylinder can be integral to $D=140$ mm. Then working pressure of oil cylinder in full load is calculated as:

$$p = 4F / \pi D^2 = 24.3 \text{MPa}$$

Taking the pressure loss of oil way into account and according to the hydraulic component, the press loss is determined as $\sum p = 1 \text{MPa}$. Ultimately, the working pressure of oil cylinder in full load is defined as

$$P = p + \sum p = 24.3 + 1 = 25.3 \text{MPa}$$

3.4 Determination of the Multi-valve Flow on Lifting System

The stroke of lifting oil cylinder is known as $s=347$ mm and he

cargo table is required to be completing 650mm lifting within 1 min, therefore, the speed of oil cylinder is:

$$v = \frac{s}{t} = \frac{347}{1} = 347 \text{ mm/min}$$

because $q = v \times A$

Where, v —the move speed of piston in lifting cylinder;
 A —the area of piston in lifting cylinder.

$$A = \pi d^2 / 4, \quad d \text{ is the diameter of lifting cylinder.}$$

Then the flow of every lifting cylinder is:

$$q = v \times A = 5.34 \text{ L/min}$$

Lifting oil cylinders are divided into two groups, then the flow of each group oil cylinder is:

$$6 \times 5.34 = 32.05 \text{ L/min}$$

hypothesis all of the lifting cylinder working in the same time with the same lifting speed, then the required flow is:

$$L_z = 12 \times 5.34 = 64.1 \text{ L/min}$$

According to the determined working pressure of lifting system and the required flow of each group, multi-way valve M4-12 of Rexroth company produced has been chosen and it has the performance with high voltage load sensitivity. Six suspension oil cylinders are controlled in each group (refer to Figure 4). This kind of multi-way valve is applied to variable pump, which it is controlled with closed core type, bus-mastering and load sensing. The using of the multi-way valve can control the lifting system accurately and make support technology of three point or four point and automatic leveling of the body coming true.

4 CONCLUSION

The principle and the characteristics of leveling according to the lifting suspension system on SPMT was analyzed. Three point leveling is adapted to uneven road surface while the four point leveling is fit for condition of unbalanced load.

A suspension leveling system is designed taking 150T SPMT as example. High precision lifting of suspension cylinder can be achieved because a closed loop control forming with electro-hydraulic proportional valves and angle sensor of Rexroth is adopted.

Load sensing proportional directional valve of leveling system can control the movement direction of suspension hydraulic cylinder which is not depended on the load. The output pressure of the pump rises with the load increasing through introducing the load sensing circuit into the variable mechanism. The energy-saving is realized because the pump's output flow is equal to the required flow of the system.

REFERENCES

[1] Zhao Jingyi, Guo Rui. Developing of independent suspension electro-hydraulic control system of heavy platform vehicle. Journal of Northeastern University. 2008, 29(52): 237-240

[2] Zhao Jingyi, Li Kan, Li Jiansong. Study on saving control for hydraulic self-propelled transporter. 7th International Conference on Fluid Power Transmission and Control (ICFP2009). 2009: P906-910

[3] Lou Huawei. Design and Simulation of Hydraulic Levelling System Controlled by Electro-hydraulic Proportional valves

[4] Lu Li-qun, Shi Bo-qiang, Guo Peng-yan, et al. Study of Control in Multi-steering Pattern of Self-propelled Heavy Platform Vehicle[J]. Coal Mine Machinery, 2008, 29(8): 164-166

[5] Kou Weiguang, Zhou Huiqun, Yang Jing. Study of Modeling Method for Hydraulic System[J]. Machinery & Electronics, 2010(5): 24-27

[6] Paynter H M. Analysis and design of engineering systems[M]. Cambridge: The MIT Press, 1960: 132-153

[7] Karnopp D, Margolis L, System R. Dynamics modeling and simulation of mechatronic systems[M]. New York: John Wiley and sons, 2005: 232-253

[8] Ren Shan. Application of load-sensing pump and proportional multi-way valve in large road machine[J]. Fluid Power Transmission and Control, 2008, 5(3): 30-31

[9] Yu Xiqing, Wu Genmao, Lu Yongxiang et al. Control mode and control performance of multi-way valve[J]. Construction Machinery and Equipment, 1995(8): 18-21

[10] Li Junxia, Kou Ziming. Characteristic analysis and simulation study of electricity-liquid proportion overflow valve[J]. Journal of China Coal Society, 2010, 35(2): 320-323